



# Tailgate Safety Training for Landscaping and Horticultural Services

Agricultural Safety Program, 590 Woody Hayes Drive, Columbus, OH 43210

## Preventing Falls

**Objective: Use safe practices to prevent falls.**

### *How to Use This Module*

Falls happen quickly and are unexpected. And they can cause serious injuries. For this module:

- Read the information provided on safety practices to prevent falls.
- Discuss problem areas in greenhouses, nurseries, and other work sites with your supervisor.
- Ask your supervisor to demonstrate safe ladder practices.
- Review the important points.
- Take the True/False quiz to check your learning.

For more information on preventing falls, refer to the Tailgate Safety Training modules *Proper Use of Ladders*, *Tree Pruning and Ladder Safety*, and *Preventing Falls From Trees*

## Background

Falls can cause serious injuries, as well as damage to facilities and equipment. Workers can fall off things or fall into openings. They can trip over obstructions or lose their footing on slippery surfaces. Some basic guidelines can help prevent falls.

## Housekeeping

- Add rubber mats to smooth-finished concrete floors.
- Clean up spills immediately.
- Use absorbent material to reduce slipping.
- Dry floors prevent slipping.
- Be alert to potential problems like:
  - ◆ Wet floors.
  - ◆ Tangled or loose hoses.
  - ◆ Moss or algae on floors.
  - ◆ Mix of water and growth media.
- Be aware of the work environment, personal safety, and the safety of co-workers.

## Floor Openings

Floor openings should be guarded by a standard fixed railing on all exposed sides. Consider using a sturdy hinged floor opening cover with removable standard railings on all exposed sides in high traffic areas.

## Ladders

- Use a ladder with two side rails joined by regularly spaced steps, rungs, or cleats, allowing for up and down movement.
- Never extend the body outside the ladder side rails.

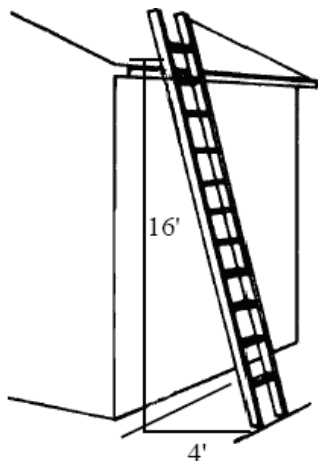

### Four-to-One Rule:

For every 4 feet of rise, the base of the ladder should be 1 foot away from the object the ladder is resting against.

- Use the Four-to-One Rule to place the ladder. Place the bottom of the ladder 1/4 of its vertical height from the building (i.e., 4 feet for 16-foot ladder).
- The top of a lean-to ladder should be 36 inches higher than the level at which the employee is working.
- Do not stand on the top two rungs of a stepladder.
- Observe the location of electrical wires. Stay clear of electrical lines and lighting fixtures.
- Keep metal ladders away from electrical wires.
- Watch out for movable equipment like portable benches or traveling booms.

## Scaffolding

Scaffolds are temporary, elevated platforms used for supporting workers and/or materials. Scaffolds must have guardrails and toe boards. Guardrails are a barrier secured to uprights and erected along the exposed sides and ends of platforms to prevent falls. Workers should use an access ladder to get up on scaffolds; they should not climb the side of the scaffold.

## Mobile Scissors Lifts

Greenhouse and nursery workers often use mobile scissors lifts in performing their jobs. If you use this type of equipment, be sure to follow the equipment safety instructions.

- Make sure all handrails and other safety devices are in place and operating.
- Be aware of other workers in the work area.
- Be aware of uneven surfaces as you move the lift.
- Be aware of beams, trusses, and gutters that may be below head level.

## Stairs

- Walk — don't run — when using stairways.
- Use handrails.
- Open, exposed stairs should have a railing. Handrails should be provided on at least one side of closed stairways, preferably on the right side descending.
- Uncluttered stairways with good tread are safest.

## General Tips to Prevent Falls

- You are more likely to slip when rushed or distracted, so do not run.
- Avoid rapid changes of direction.
- Keep floors in good repair.
- Wear shoes with pliable soles and low heels.
- Close open drawers, cabinets, doors, or closets after use.
- Watch out for movable equipment like portable benches or traveling booms.

## Review These Important Points

- Keeping the work area free of spills helps prevent slips and falls.
- All open spaces should have a fixed railing around them.
- Always use an approved ladder.
- Scaffolding must have guardrails and toe boards.

## About These Modules

The author team for the training modules in the landscape and horticultural tailgate training series includes Dee Jepsen, Program Director, Agricultural Safety and Health, Ohio State University Extension; Michael Wonacott, Research Specialist, Vocational Education; Peter Ling, Greenhouse Specialist; and Thomas Bean, Agricultural Safety Specialist. Modules were developed with funding from the Occupational Safety and Health Administration, U.S. Department of Labor, Grant Number 46E3-HT09.

Any opinions, findings, conclusions, or recommendations expressed in this publication are those of the author(s) and do not necessarily reflect the views of the U.S. Department of Agriculture or the U.S. Department of Labor.

Answer Key: 1 = T, 2 = T, 3 = F, 4 = T, 5 = T.

OSU Extension embraces human diversity and is committed to ensuring that all educational programs conducted by Ohio State University Extension are available to clientele on a nondiscriminatory basis without regard to race, color, age, gender identity or expression, disability, religion, sexual orientation, national origin, or veteran status.

Keith L. Smith, Associate Vice President for Agricultural Administration and Director, Ohio State University Extension

TDD No. 800-589-8292 (Ohio only) or 614-292-1868

Copyright © 2006, The Ohio State University



EXTENSION

# Tailgate Safety Training for Landscaping and Horticultural Services

Agricultural Safety Program, 590 Woody Hayes Drive, Columbus, OH 43210

## Preventing Falls

*Name* \_\_\_\_\_

### True or False?

- |   |   |   |
|---|---|---|
| 1. To prevent slipping, all floors should be kept dry.  | T | F |
| 2. Use an approved ladder.  | T | F |
| 3. Shop floors and steps are safe storage areas.  | T | F |
| 4. When spills occur in the shop, it is best to use an absorbent material to reduce slipping. | T | F |
| 5. Being alert is one of the surest ways to avoid falls.                                      | T | F |