



AEX-390-08

Farm Pond Safety

Thomas L. Bean

Department of Food, Agricultural, and Biological Engineering

The farm pond has been an important economic unit in many farming programs. Ponds are used as part of a soil and water conservation program to water livestock, as an irrigation water source, and for fire protection and recreation, such as fishing, boating, swimming, and ice skating.

Unfortunately, farm ponds contribute to accidental drownings. The majority of victims of farm pond drownings are children. Small children get too close to the water and lose their balance on the soft bank. Many wade in the cool shallow water only to fall into deep holes.

Lack of close adult supervision contributes to pond drownings. Adults often underestimate a child's curiosity. A short attention span, coupled with the attractiveness of a farm pond as a play area may render most verbal instructions ineffective.

It is the farm operator's responsibility to see that his/her farm pond is as safe as possible. In most cases it is recommended that all ponds be fenced and posted to keep out unwanted persons. Liability may increase with non-posted, non-fenced ponds. Restrict entry to your pond to keep out uninvited guests.

Accidents can be prevented and lives saved by placing signs warning of specific dangers or indicating safe areas for swimming.

All farm ponds used for swimming should have a rescue post. It should be set firmly in the ground near the water. The post should be painted yellow. Attach a long shelf bracket, peg, or nail to the post.

Obtain enough nylon rope to reach across the pond. Attach a life buoy or ring to one end of the rope and a wooden block to the other end. Hang this rescue device on the post. A thin, lightweight 12' to 14' pole should be attached to the rescue post to aid in rescue. Finally, attach the location of the nearest telephone and emergency numbers to the top of the post.

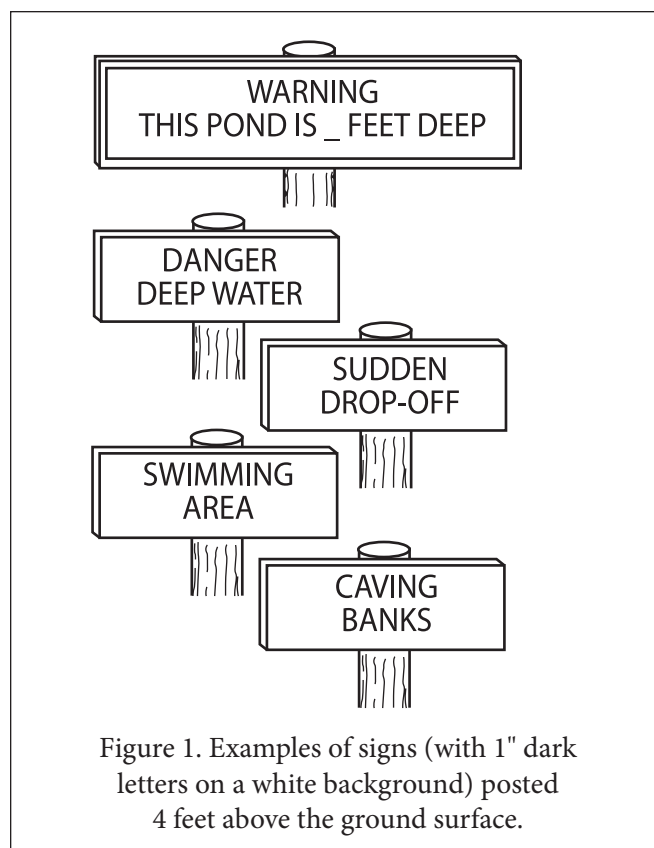
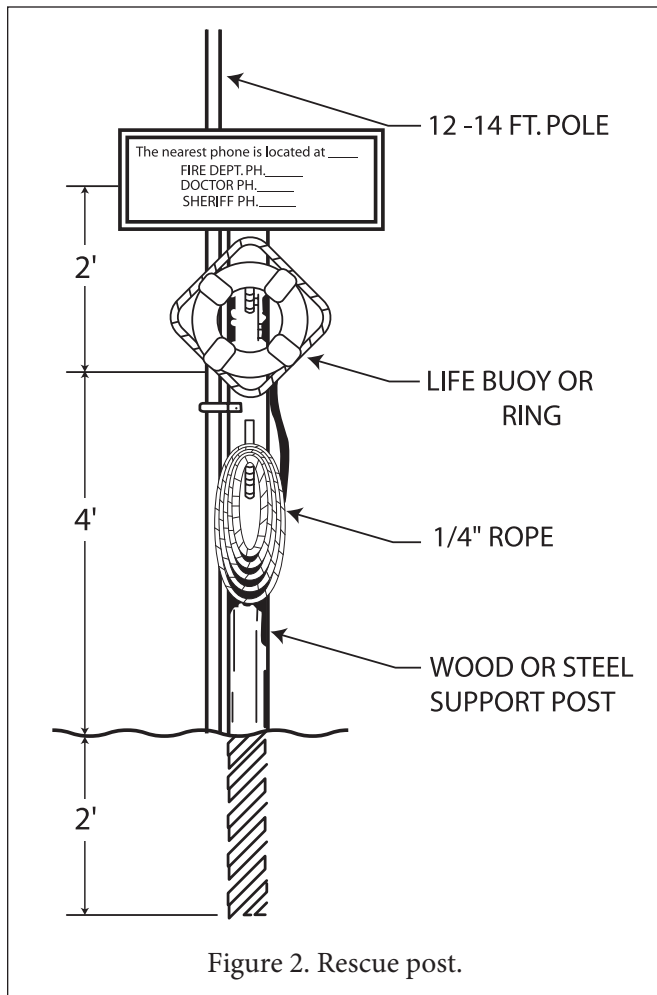

Figure 1. Examples of signs (with 1" dark letters on a white background) posted 4 feet above the ground surface.



It should be emphasized that all farm ponds may not be suitable for swimming. If the water is cloudy, has a foul odor, or has excess algae, it may contain infectious agents or be contaminated by fertilizers, pesticides, or livestock wastes. Ponds used for swimming should be analyzed for bacteria during swimming season to determine water quality. Contact your county office of Ohio State University Extension for publications AEX 314, *Water Testing* and AEX 315, *Where to Have Your Water Tested*.

Make Your Farm Pond Safe for Swimming

- DO** teach children to swim.
- DO** mark safe swimming areas with posts or floats.
- DO** remove submerged rocks, stumps, broken bottles, and other hazards.
- DO** keep simple rescue devices near your pond.
- DO** post life saving warning signs.
- DO** have your pond tested for contamination.
- DON'T** swim alone or allow anyone to swim by themselves.
- DON'T** let small children swim near a farm pond without adult supervision.

Reviewed by Dr. Karen Mancl and Dr. Andy Ward, Department of Food, Agricultural, and Biological Engineering.

Funded in whole or in part from Grant Number U05/CCU506070-03, "Cooperative Agreement Program for Agricultural Health Promotion Systems," National Institute for Occupational Safety and Health.

EMPOWERMENT THROUGH EDUCATION

Visit Ohio State University Extension's web site "Ohioline" at: <http://ohioline.osu.edu>

Ohio State University Extension embraces human diversity and is committed to ensuring that all research and related educational programs are available to clientele on a nondiscriminatory basis without regard to race, color, religion, sex, age, national origin, sexual orientation, gender identity or expression, disability, or veteran status. This statement is in accordance with United States Civil Rights Laws and the USDA.

Keith L. Smith, Ph.D., Associate Vice President for Agricultural Administration and Director, Ohio State University Extension

TDD No. 800-589-8292 (Ohio only) or 614-292-1868